

PHILIPS

DIRECTIONS FOR USE

AIR-ENGINE GENERATOR MP 1002 CA

C O N T E N T S

	Page
DESCRIPTION	1
Working of the air engine	1
Characteristics and advantages	3
TECHNICAL DATA	4
Engine	4
Generator	4
Generating set	4
Ventilation	4
TRANSPORT	5
OPERATION	6
Starting up	6
Pumping	7
Stopping	7
Starting when the pressure tank is not charged	7
Important	8
OPERATION (Condensed Version)	9
SYSTEM OF PIPES AND LINES SHOWN IN DIAGRAMMATIC FORM ^{*)}	-
ACCESSORIES ^{*)}	-
CHECKING THE GENERATING SET	10
Electrical capacity	10
Fuel consumption	10
MAINTENANCE	11
Lubricant	11
Tension of the belt	13
Cleaning	13
Overhaul	14
RECTIFICATION OF FAULTS WHICH MAY OCCUR IN USE ^{*)}	-

^{*)}To be dealt with separately.

PHILIPS AIR-ENGINE GENERATOR

TYPE MP 1002 CA

DESCRIPTION

This Philips generating set comprises a single-cylinder air-engine and a generator, supplying a full-load rating of 180 watts at 220 V, 50 c/s. The nominal engine speed is 1500 and the nominal generator speed 3000 r.p.m.

WORKING OF THE AIR ENGINE

The Philips air engine is an external combustion engine, and since work is performed at every complete revolution of the engine shaft it has a two-stroke cycle.

The external combustion of the fuel (kerosine, or non-leaded gasoline) takes place continuously in the burner supplying heat to the annular-shaped heater, which is provided with fins both on the outside and on the inside. Combustion products do not enter the cylinder, because the cylinder is completely closed off.

Below the heater is a cooler, likewise annular in shape and placed around the cylinder, which is externally cooled with air by means of a fan driven by the engine itself.

Inside the cylinder is a power piston and a transfer piston, both of which are coupled to the crankshaft via a driving mechanism. The movement of the transfer piston is always about a quarter of a complete revolution in advance of the movement of the power piston. The transfer piston separates the "hot" space in the cylinder, communicating with the heater, from the "cold" space, which is in communication with the cooler. The transfer piston displaces the air via the heater, the regenerator and the cooler from the "hot" space to the "cold" one and vice versa. The regenerator serves to extract the heat from the air flowing from the heater to the cooler, to store it, and to give it off again when the air is flowing in the reverse direction. The transfer piston has an insulating cap to prevent the conduction of heat to the cold space and the bearing surface in the cylinder. The connecting rod of the transfer piston passes through the centre of the power piston. Only the latter exercises a driving force upon the crankshaft.

Coupled to the driving mechanism is a small, one-stage compressor providing the air pressure in the cylinder and the crankcase. A release valve ensures that the desired pressure is maintained in the crankcase and the cylinder.

For each revolution of the crankshaft the cycle of operation performed in the cylinder consists of the following four phases:

- I. Compression of cold air in the cold space.
- II. Heating of the compressed air in the regenerator and the heater.
- III. Expansion of the hot air in the hot space.
- IV. Cooling of the expanded air in the regenerator and the cooler.

During the compression (phase I) energy will be supplied to the air by the power piston, which it derives from the flywheel, while during the expansion (phase III) the power piston receives energy from the air.

Compression takes place at a low temperature and expansion at a high temperature and high pressure (the elevation of temperature by the heater raises the pressure still higher), so that more power is delivered by the expansion than is consumed by the compression. Thus heat supplied by the burner to the engine is converted into power.

The movements of the power and the transfer piston can be followed with the aid of fig. 1a, a schematic cross-section of a single-cylinder air engine.

Phase I, compression: The power piston Z moves upward from its bottom dead-centre, while the transfer piston P moves towards its top dead-centre, the air in the cold space V_k thus being compressed.

Phase II, heating: The power piston Z moves upward towards its top dead-centre, while the transfer piston P moves downward, thus displacing the air from the cold space V_k via the cooler K, the regenerator R and the heater H to the hot space V_w .

Phase III, expansion: The power piston Z moves downward and also the transfer piston P, because of the expansion of the compressed air, heated in the regenerator R and the heater H.

Phase IV, cooling: The power piston moves towards its bottom dead-centre while the transfer piston P moves upward, displacing the expanded air from the hot space V_w to the cold space V_k , thereby giving off its heat in the regenerator R and the cooler K.

CHARACTERISTICS AND ADVANTAGES

The Philips air engine is characterized by a number of favourable properties making it particularly suitable for various purposes. Among others, it possesses the following characteristics:

1. Non-critical on fuel specification (cf. the diverging properties of kerosine and non-leaded gasoline).
 2. Silent operation, no explosions, no valve noise; the combustion is continuous. Non-poisonous flue gases.
 3. Uniform torque owing to uniform expansion, and an extremely uniform load on the driving gear.
 4. Little wear, because the piston walls do not come into contact with the combustion products.
 5. Low friction losses.
 6. Extremely low lubricant consumption and no contamination of the oil, partly because the temperature of the sliding surfaces of the piston walls is kept low.
 7. Long life. The engine can be left running for long periods without supervision.
 8. Great reliability.
 9. Simple operation and little maintenance.
 10. Constant speed, independent of load; no readjusting needed.
- Conservation of energy at high altitudes.

TECHNICAL DATA

ENGINE

- Fuel: 1. Kerosine; the jet is set on delivery for kerosine with a specific gravity of 8.
2. Gasoline (free of lead tetraethyl); this has a lower specific gravity than kerosine and requires a different jet setting; it dispenses with pre-heating (with the choke closed, the burner can be ignited directly).

Fuel consumption (kerosine)	: about 0.4 litre per hour
Fuel tank capacity	: about 3.3 litres.
Running hours per filling	: about 8
Lubricant	: Shell Turbo 27 or Vacuum Arctic; SAE 20.
Lubricant capacity in crankcase	: about 0.16 litre
Engine speed, nominal	: 1500 r.p.m.

GENERATOR

Current	: A.C.
Power (full load)	: 180 W
Voltage (nominal)	: 220 V
Current (maximum)	: 1 A x)
Frequency (nominal)	: 50 c/s
Generator speed (nominal)	: 3000 r.p.m.

x) A 1-A fuse has to be connected in the circuit. If desired a 1-A maximum-current relay can be used.

GENERATING SET

Weight (without fuel)	: about 30 kg
Dimensions	: length: 45 cm, width: 27 cm, height: 40 cm

VENTILATION

If this generating set is installed in a closed space provision has to be made for an adequate supply of fresh air for the burner, while gases from the cooler have to be carried off through a flue, e.g. in the form of a vapour cap.

TRANSPORT

As a precautionary measure the unit is delivered without lubricant in the crankcase and with an empty fuel tank, as it is quite likely that the engine during transport may be placed upside down. Therefore, before starting up for the first time, the crankcase has to be filled with lubricant as specified in the chapter "MAINTENANCE".

OPERATION

STARTING UP

I. Preheating the burner (evaporator), see fig. 2.

Open the fuel cock B (handle vertical). Open the valve (2) of the pressure tank (serving also as carrying frame) wide and with an already-lighted hurricane match, lighter, or torch soaked with the fuel, ignite the fuel jet through the opened choke L.

The evaporator will be sufficiently heated when the air pressure in the pressure tank - read from the manometer (M) - has dropped 20-25 lbs., say from 200 to about 175 lbs., which takes about 45 seconds. If after that time the lighted jet should suddenly go out, then the right temperature will already have been reached and the heater can be ignited in the aperture (V).

II. Warming up the heater

If the fuel jet continues burning after 45 seconds, then it has to be extinguished by closing the choke (L) (if necessary, however, also close the valve (2) for a moment); then ignite the burner at V with a hurricane match, lighter or torch. The mist rising from the burner at V will then disappear; rising heat is perceptible.

(After the burner has been ignited no green flames should be seen through the opening for the exhaust gas. If there are any flames, blow through the opening. A red sphere may be seen.)

Next directly open the choke (L). After that open the valve (1) to let air into the engine from the compressor; the manometer will indicate this by a sudden drop in the pressure over a period of one or two seconds. Then close the valve (2). The heater will have reached a sufficiently high temperature when the manometer pressure has dropped to about 65 lbs. Especially at low ambient temperatures, we recommend continuing the heating sufficiently long to achieve this.

III. Starting the engine

The engine is started by laying the starting cord, with the button outside, one turn clockwise in the groove of the start disc of the flywheel and then pulling it off with a sharp jerk. Do not try to start the engine under load!

The engine itself can now supply air to the burner, therefore open valve (1) and after that close valve (2). The load can be switched on too. If the engine is started up too soon, i.e. before the working temperature has been reached, it will not immediately gain full speed.

PUMPING

To charge the pressure tank open valve (3); valve (2) remains closed. When the manometer shows a pressure of at least 200 lbs. then valve (3) can be closed. During the pumping the electrical load should be switched off. We recommend the charging of the pressure tank immediately after starting the engine, as then sufficient pressure for the next start will always be available.

STOPPING

Switch off the load and close valve (1). The engine will continue to run for a while owing to the heat still present in the heater and the air pressure in the cylinder. If the engine is not anchored it should be held during running down.

To cool the heater, it is advisable to let the engine completely run down. If the engine is suddenly stopped, the heat, still present in the heater, will in the long run damage the cylinder-head packing. Finally make sure that the valves (1), (2) and (3) are properly closed. Before transportation or if the engine is taken out of use for any length of time, the fuel cock should be closed (handle horizontal) while the engine is running; this is to empty the float chamber. After that close valve (1). This obviates fouling with fuel. Further, the choke should be closed to keep dust out of the fuel nozzle of the burner. As an additional precaution make a practice of draining off the oil-water separator after every stop by unscrewing the drainer "A" a couple of turns; after draining screw it up again.

STARTING WHEN THE PRESSURE TANK IS NOT CHARGED

If, for some reason or other, the charging of the pressure tank has been omitted (the manometer will then show little or no pressure) the engine can be started with the aid of a pedestal or hand pump connected to the nipple P.

The normal procedure is then followed except that while preheating the burner (step I) and warming up the heater (step II) pumping has to be kept up steadily, and valve (1) has to be opened instead of valve (2); there are no other manipulations of the valves until the engine starts running.

IMPORTANT

If the generating set has been out of use for a pretty long time, it might be possible that the engine will not gain full speed after starting. In that case you must slant the engine a little to the fly-wheel side, in order to fill the shaft sealing with oil.

OPERATION (Condensed Version)

S T A R T I N G	VALVE		OPERATION	MANOMETER	
	No.	Position		Begin	End
Preheating burner (about 45 sec)	2	O	Ignite jet (flame out!)	approx. 200	-
	choke (2)	C		-	175
Warming up heater	2	O	ignite burner	175	-
	choke	O	and		
	1	O→C	fill engine with air	(175)	(120)
	-	-	start engine at	-	65
Starting engine	-	-	(unloaded!) with starting cord	65	-
	1	O	connecting com-		
	2	C	pressor to burner	-	approx. 50
	-	-	switch on load	-	-

P U M P I N G	3	O→C	Charge pressure tank (switch load off)	approx. 50	approx. 200
---------------	---	-----	--	------------	-------------

S T O P P I N G	1	C	burner off		approx. 200
-----------------	---	---	------------	--	-------------

Every time the engine is stopped, or with continuous operation, every 24 hours, unscrew the drainer of the oil separator a couple of turns and screw it up again after draining.

Notes:

- 1) O = Valve open.
C = Valve closed.
- 2) The manometer readings given in the above table serve only as a guide.
- 3) When the engine is not in use and during transportation close both the fuel cock and choke. Preferably stop by closing the fuel cock, thus emptying the float chamber.

DO NOT FORGET TO REFILL WITH FUEL AND EVERY 50 HOURS TO TOP UP WITH OIL OR RENEW THE OIL AS DIRECTED!

CHECKING THE GENERATING SET

ELECTRICAL CAPACITY

The voltage without load and the voltage at load can be checked by means of a voltmeter and an ammeter (magnetic types). Five bulbs of 40 W (220 V) are to be taken as representing full-load.

By measuring and writing down periodically (e.g. once a week or once a fortnight) the supplied electrical wattage and the voltage at no-load, one will be able to keep in a simple manner (viz. by comparing them with the original values) a check of the reliable functioning of the engine. By measuring the voltage without load, the number of revolutions of the engine at no-load can be checked because it is proportional to the number of revolutions of the dynamo. When the wattage at full-load supplied by the generator decreases over a long period, the cause will generally be fouling of the burner and of the cooling system. Cleaning of the burner, the heater head and the fan gauze will be necessary, see chapter "MAINTENANCE".

FUEL CONSUMPTION

Checking the fuel consumption is important in view of its relationship to the power supplied.

The consumption can be checked in a very simple manner by carrying out a time measurement by means of a watch provided with a secondhand. The engine has to run at normal operation temperature, whilst the load must be switched off in connection with the running of the engine, when the fuel is consumed. Measure now the time between the closing of the fuel cock under the fuel tank and the stopping of the fuel jet out of the atomizer, which can be kept in view through the opened choke. Then open the fuel cock and ignite the burner again through the opening in the top. A higher degree of precision can be obtained by calculating the average of three measurements.

By comparing this time with the value given on the data-card, supplied with the engine, you will have a reliable check.

A time deviation in this matter could be an indication of fouling: clean the engine as described in the chapter "MAINTENANCE".

The factory-adjustment of the engine must not be altered!

MAINTENANCE

When the engine is used under normal conditions the oil level has to be topped up (or the oil has to be changed) once a week.

As the required maintenance and the cleaning described in the next chapter are dependent on the conditions under which the engine is operating, we will give you here a scheme based on continuous operation under average conditions, as a guide for the arrangement of your own scheme.

LUBRICANT

Shell Turbo 27 or Vacuum Arctic, SAE 20, is recommended for summer and winter. The oil capacity of the crankcase is about 0.16 litre. Good lubrication is all-important for the life of the engine, so always keep the crankcase topped up with oil, and change the oil at regular intervals.

Every 24 running hours

Drain off the oil separator

Unscrew the drainer (A), see fig. 2, a couple of turns and then screw it up again.

If the oil separator is not drained off, then, owing to the oil reaching too high a level, oil may be carried along by the burner air into the atomizer and cause trouble. It is therefore advisable to make a practice of draining off the oil separator each time the engine is stopped.

Every 50 running hours

Top up with oil

1. Screw the plug (11) out of the crankcase (any compressed air should be let out gradually).
2. Fill up with oil to the bottom rim of the filling opening (assuming the engine is horizontal).
3. Screw in again the plug (11), not forgetting the packing ring; the latter makes a perfect seal without the plug having to be screwed in too tight.

Empty the oil collector

Empty the oil collector (12) which catches the oil from the separator, the condensation water from the pressure regulating unit and any oil leaking from the shaft sealing.

Blow off low and high pressure

To delay cleaning the engine as long as possible, it is recommended to blow off the low and the high pressure at least once a week.

This has to be done with something long and thin (for instance a match), used to successively push in the two nipples, to be seen at the right-hand side of valve (1). Any deposits will then be blown away.

Every 200 running hours

Change the oil

Preferably always drain the oil out of the crankcase while the motor is warm, e.g. immediately after stopping the engine.

1. Close the fuel cock. If the fuel tank is filled, the engine must not be slanted too far over to one side.
2. Screw the plug (11) out of the crankcase (any compressed air should be let out gradually).
3. Remove the oil collector (12).
4. Screw the plug (13) which is now visible out of the crankcase and let the oil run out.
5. Flush the engine with paraffin oil via opening (11).
6. Carefully clean plug (13) with paraffin oil, because this plug serves also for lubricating purposes.
7. Put back the plug (13) in the crankcase, not forgetting the packing ring, which makes tight screwing-in unnecessary.
8. Empty the oil collector (12) and put it back in place. Guide the exhaust connections again into the opening of the oil collector.
9. Fill the crankcase up with fresh oil via opening (11) as described under "Top up with oil".

Note: With a new engine, or after an overhaul, the oil has to be changed after 25, 50, 100 and 200 running hours consecutively; this can be done every 200 running hours.

TENSION OF THE BELT

If after some time the belt causes a rattle, then most likely it has stretched a little. It can be made taut again by placing the generator at a greater distance from the engine, slotted holes are provided for this purpose.

The tension of the belt can be checked quite simply by pushing with a slight pressure of the hand on the middle of the belt.

There should be about 2 cms of slackness.

CLEANING

To ensure a constantly full output from the engine it must be kept always scrupulously clean. Therefore:

Every 100 running hours

Clean the filter in the float chamber

1. Close the fuel cock.
2. Unscrew the float screw (14), see fig. 2.
3. Take out the filter and clean it in paraffin oil or gasoline.
4. Put back the filter.
5. Tighten up the float screw (14), not forgetting the packing ring.

Every 200 running hours (or more frequently if the generating set is erected in dirty surroundings)

Clean the fan gauze (the engine must not be running!)

1. Loosen the four fixing screws (15), see fig. 2.
2. Take out the gauze and clean it with a brush.
3. Put back the gauze and secure it with the screws.

Every 500 running hours

Clean the burner and the heater head

1. Detach the fan tube (1), see fig. 4, from the atomizer (2).
2. Unscrew the cap nuts on the pipes (3) and (4).
3. Take the filters out of the pipes (3) and (4) and clean them in paraffin oil.
4. Dismount the atomizer (2) by unscrewing the two screws (2a).
5. Remove the three nuts (5) from underneath the burner plate (6) and take off the burner.

6. Unscrew the three screws (11) from the burner housing (7) and remove the burner cap (10).
7. Clean the flame baffle (8) and heater head (9) with a hard (e.g. nylon) brush.
8. Carefully clean the atomizer (2) in paraffin oil and clear it thoroughly by blowing through it.
9. Reassemble everything in the reverse order.

Stopped-up jet

If the jet, notwithstanding the filters, should nevertheless become stopped up, proceed as follows:

1. Unscrew the two screws holding the atomizer (2) in place and loosen it.
2. Prick the jet orifice (at A) with a thin wire, for instance taken from an electrical flex and after unscrewing the screw at B also prick this hole.
3. Remount the atomizer.

OVERHAUL

Every 1000 running hours

Small overhaul: Clean the whole of the engine and replace any worn gudgeon pins.

Among others, the reducing valve and the maximum-pressure valve should be examined, the fuel tank cleaned out and the brake drum cleaned (e.g. with paraffin oil) and lubricated with a light grade of oil.

Every 2000 running hours

Major overhaul: Give the engine a thorough overhaul, inspecting all parts and putting in replacements where necessary.

Supplement to the Directions for Using the

AIR-ENGINE GENERATOR

MP 1002 CA

Improvements made before dispatch of the unit:

1. On the fuel injection nozzle, directly in front of the burner, a by-pass valve has been placed, which ensures that during starting a smaller amount of fuel will be sucked by the air-jet from the reservoir. (Trouble has been encountered that whilst starting, the amount of fuel is too great for the then available combustion air volume, as the fan does not deliver any air during starting. By slightly spoiling the vacuum in the mixing point (high speed air-fuel at the nozzle) the amount of fuel is reduced.)

During starting (motor not yet running) this by-pass valve should be open (high position of the valve stem). This valve must be closed (low position of valve stem) at the moment that the engine is turning at full revolutions.

This by-pass valve also gives the possibility of saving fuel at longer periods of low-load.

2. To allow a correction of the amount of combustion air, if the burner resistance increases due to fouling - a scoop has been fitted at the right-hand side of the fan, which can be shifted in its position with respect to the connection pipe between fan and burner.

By moving this scoop downwards (loosen big nut on fan housing behind the air reservoir and push scoop downwards) the flow of secondary air from the fan to the burner is increased.

On the moment that the burner starts to smell, the scoop should be pushed down; if, by this alteration the flame should become visible at the top of the motor (exhaust funnel) the scoop should be pushed slightly upwards again until this flame just disappears; the scoop should then be refixed.

3. It is possible that in the long run the cooler resistance will increase, due to fouling. Means have now been provided to make cleaning easier by constructing the cooling-air housing (round the cooler) into two halves.

If the temperature of the cooler increases above the normal figure and the engine output drops, the cooler should be checked and, if necessary, cleaned. To do the latter effectively the burner should be removed.

If fouling of the cooler occurs frequently a low-resistance filter should be fitted in front of the air-intake of the fan, or an air suction line should be fitted to take in clean atmospheric air, or the whole unit should be removed to a place where clean air is available.

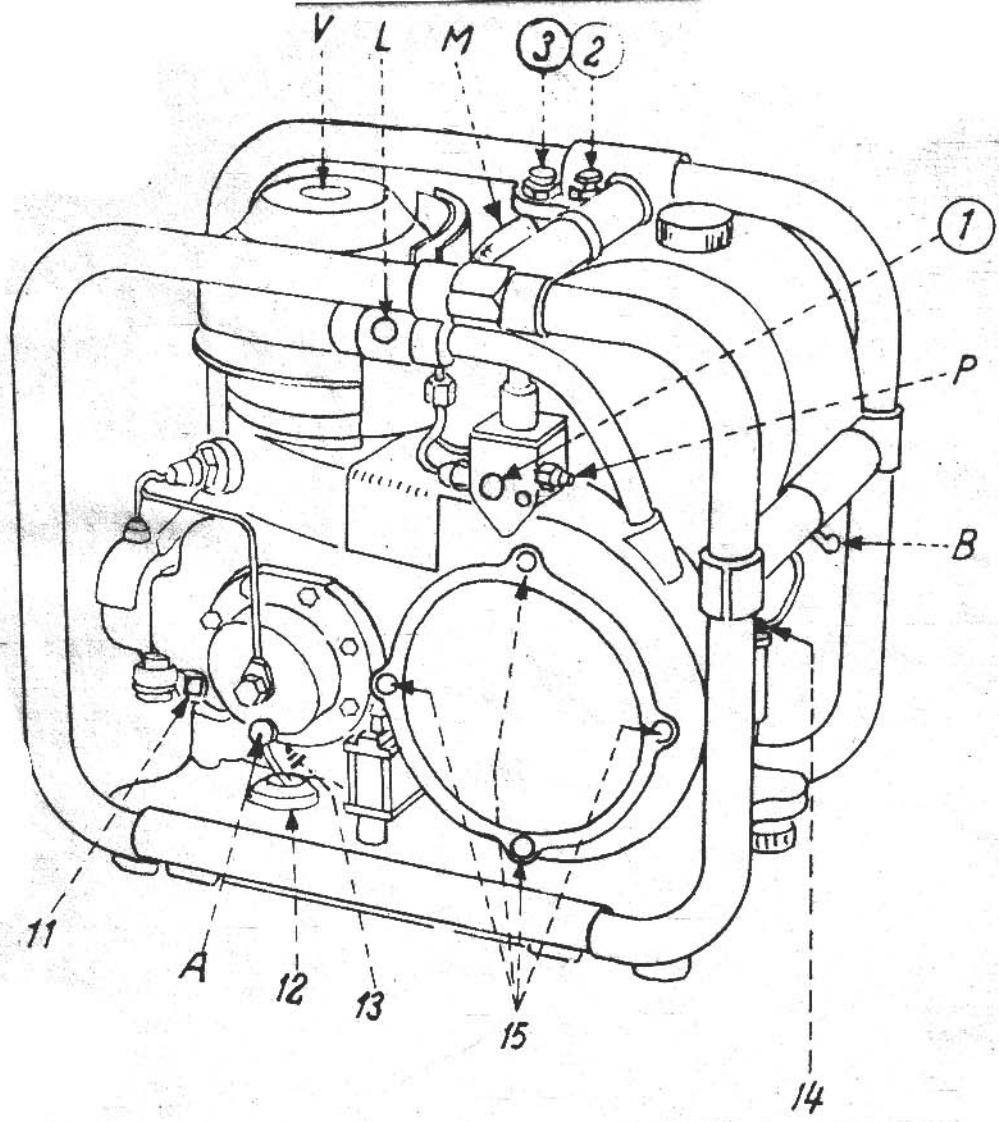

Fig. 2

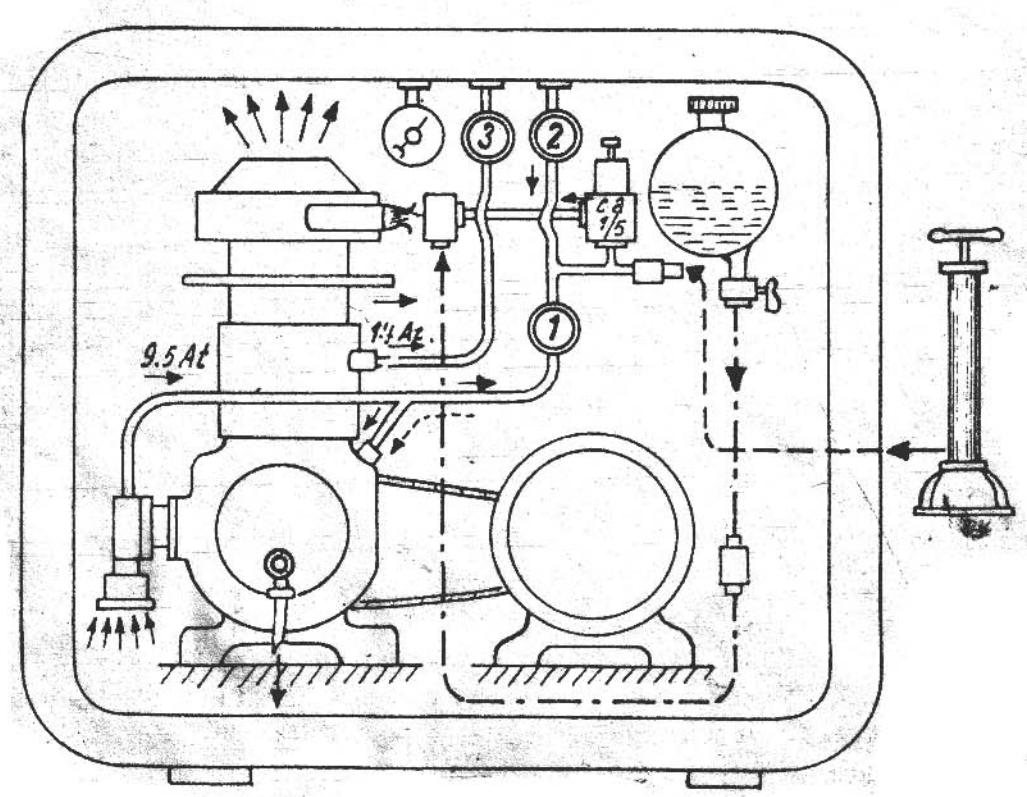

Fig. 2a

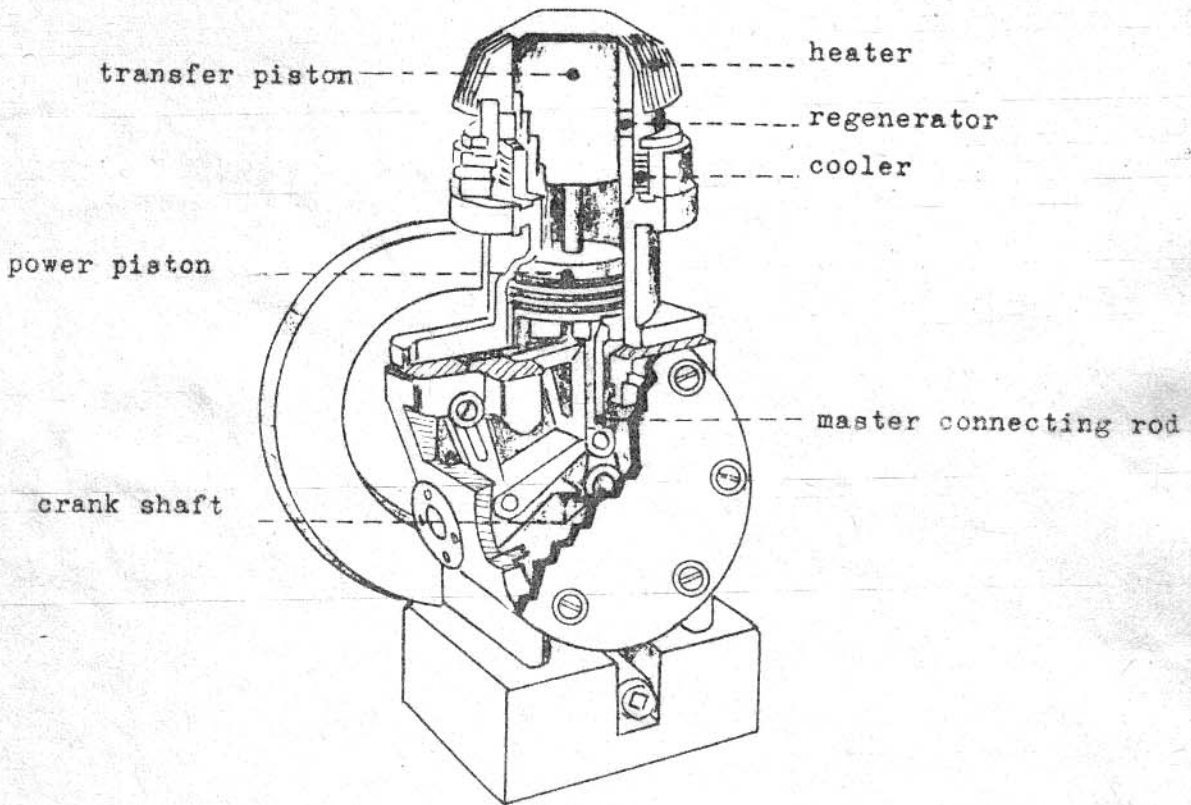

Fig. 1b - Principle of the air engine shown in a more realistic form than in fig. 1a.

Fig. 1a - Simplified diagram of the air engine. The heater, regenerator and cooler are shown for clarity at one side of the cylinder and not around it.

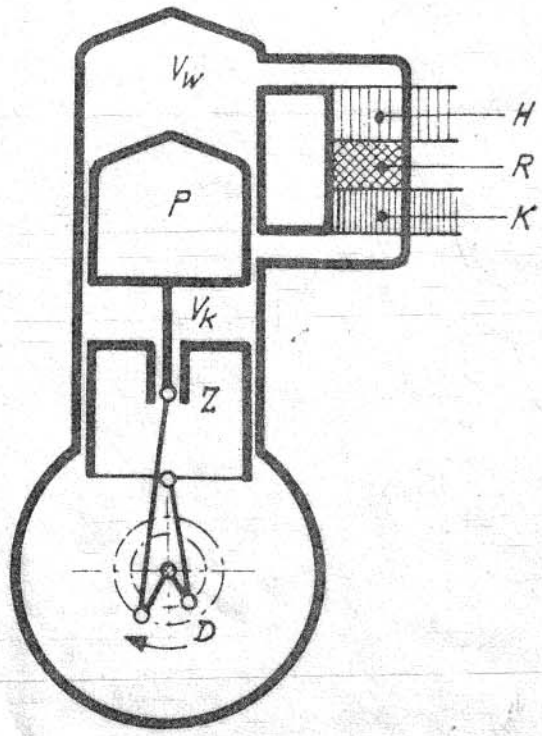

Fig. 4

